

10 TON BENDER ATTACHMENTS

PIPE BENDER DIES

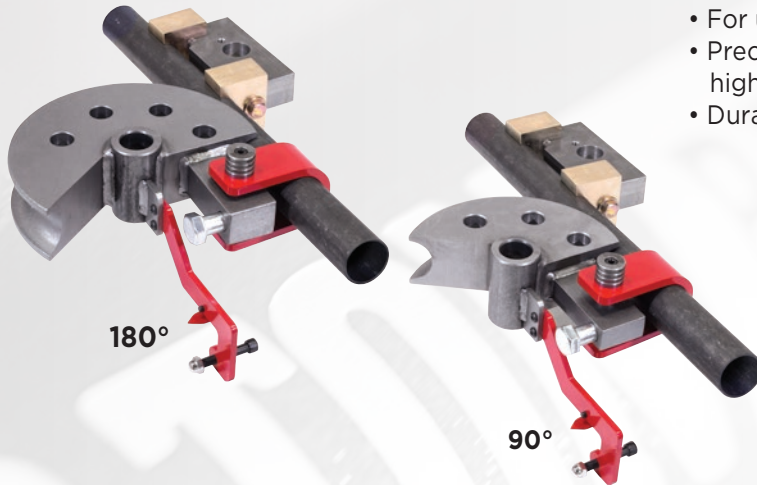

- For use with Edwards 10 Ton Bender
- Precision machined components to ensure the highest quality bends
- Durable brass follower provides extra long life

PIPE BENDER DIES 180°										
BEND RADIUS	3"	3.5"	4"	4.5"	5"	5.5"	6"	6.5"	7"	7.5"
PIPE SIZE										
1/4"	PBD180/.25X3	PBD180/.25X3.5								
3/8"	PBD180/.375X3	PBD180/.375X3.5								
1/2"	PBD180/.5X3	PBD180/.5X3.5	PBD180/.5X4	PBD180/.5X4.5						
3/4"	PBD180/.75X3	PBD180/.75X3.5	PBD180/.75X4	PBD180/.75X4.5		PBD180/.75X5.5		PBD180/.75X6.5		
1"	PBD180/1X3	PBD180/1X3.5	PBD180/1X4	PBD180/1X4.5	PBD180/1X5	PBD180/1X5.5	PBD180/1X6	PBD180/1X6.5		PBD180/1X7.5
1-1/4"		PBD180/1.25X3.5	PBD180/1.25X4	PBD180/1.25X4.5	PBD180/1.25X5	PBD180/1.25X5.5	PBD180/1.25X6	PBD180/1.25X6.5	PBD180/1.25X7	
1-1/2"				PBD180/1.5X4.5	PBD180/1.5X5	PBD180/1.5X5.5	PBD180/1.5X6	PBD180/1.5X6.5	PBD180/1.5X7	PBD180/1.5X7.5
2"						PBD180/2X5.5	PBD180/2X6	PBD180/2X6.5		PBD180/2X7.5

PIPE BENDER DIES 90°										
BEND RADIUS	3"	3.5"	4"	4.5"	5"	5.5"	6"	6.5"	7"	7.5"
PIPE SIZE										
1/4"	PBD90/.25X3	PBD90/.25X3.5								
3/8"	PBD90/.375X3	PBD90/.375X3.5								
1/2"	PBD90/.5X3	PBD90/.5X3.5	PBD90/.5X4	PBD90/.5X4.5						
3/4"	PBD90/.75X3	PBD90/.75X3.5	PBD90/.75X4	PBD90/.75X4.5		PBD90/.75X5.5		PBD90/.75X6.5		
1"	PBD90/1X3	PBD90/1X3.5	PBD90/1X4	PBD90/1X4.5	PBD90/1X5	PBD90/1X5.5	PBD90/1X6	PBD90/1X6.5		PBD90/1X7.5
1-1/4"		PBD90/1.25X3.5	PBD90/1.25X4	PBD90/1.25X4.5	PBD90/1.25X5	PBD90/1.25X5.5	PBD90/1.25X6	PBD90/1.25X6.5	PBD90/1.25X7	
1-1/2"			PBD90/1.5X4	PBD90/1.5X4.5	PBD90/1.5X5	PBD90/1.5X5.5	PBD90/1.5X6	PBD90/1.5X6.5	PBD90/1.5X7	PBD90/1.5X7.5
2"						PBD90/2X5.5	PBD90/2X6	PBD90/2X6.5		PBD90/2X7.5

TUBE BENDER DIES

TUBE BENDER DIES 180°													
BEND RADIUS	2"	2.25"	2.5"	3"	3.5"	4"	4.5"	5"	5.5"	6"	6.5"	7"	7.5"
PIPE SIZE													
1/2"	TD180/.5X2	TD180/.5X2.25	TD180/.5X2.5	TD180/.5X3			TD180/.5X4.5						
5/8"		TD180/.625X2.25	TD180/.625X2.5	TD180/.625X3	TD180/.625X3.5								
3/4"		TD180/.75X2.25	TD180/.75X2.5	TD180/.75X3	TD180/.75X3.5	TD180/.75X4	TD180/.75X4.5		TD180/.75X5.5		TD180/.75X6.5		
7/8"			TD180/.875X2.5	TD180/.875X3	TD180/.875X3.5	TD180/.875X4	TD180/.875X4.5		TD180/.875X5.5				
1"				TD180/1X3	TD180/1X3.5	TD180/1X4	TD180/1X4.5		TD180/1X5.5	TD180/1X6	TD180/1.0X6.5		TD180/1X7.5
1-1/8"				TD180/1.125X3	TD180/1.125X3.5	TD180/1.125X4	TD180/1.125X4.5		TD180/1.125X5.5				
1-1/4"					TD180/1.25X3.5	TD180/1.25X4	TD180/1.25X4.5	TD180/1.25X5	TD180/1.25X5.5	TD180/1.25X6	TD180/1.25X6.5	TD180/1.25X7	
1-3/8"							TD180/1.375X4.5	TD180/1.375X5	TD180/1.375X5.5	TD180/1.375X6	TD180/1.375X6.5		TD180/1.375X7.5
1-1/2"							TD180/1.5X4.5	TD180/1.5X5	TD180/1.5X5.5	TD180/1.5X6	TD180/1.5X6.5	TD180/1.5X7	TD180/1.5X7.5
1-5/8"									TD180/1.625X5.5	TD180/1.625X6	TD180/1.625X6.5	TD180/1.625X7	TD180/1.625X7.5
1-3/4"									TD180/1.75X5.5	TD180/1.75X6	TD180/1.75X6.5	TD180/1.75X7	TD180/1.75X7.5
1-7/8"										TD180/1.875X6	TD180/1.875X6.5	TD180/1.875X7	TD180/1.875X7.5
2"									TD180/2X5.5	TD180/2X6	TD180/2X6.5	TD180/2X7	TD180/2X7.5
2-1/8"											TD180/2.125X6.5		TD180/2.125X7.5
2-1/4"											TD180/2.25X6.5		TD180/2.25X7.5
2-3/8"											TD180/2.375X6.5		TD180/2.375X7.5
2-1/2"											TD180/2.5X6.5		TD180/2.5X7.5

TUBE BENDER DIES 90°												
BEND RADIUS	2.25"	2.5"	3"	3.5"	4"	4.5"	5"	5.5"	6"	6.5"	7"	7.5"
PIPE SIZE												
1/2"	TD90/.5X2.25	TD90/.5X2.5	TD90/.5X3				TD90/.5X4.5					
5/8"	TD90/.625X2.25	TD90/.625X2.5	TD90/.625X3	TD90/.625X3.5								
3/4"	TD90/.75X2.25	TD90/.75X2.5	TD90/.75X3	TD90/.75X3.5	TD90/.75X4	TD90/.75X4.5		TD90/.75X5.5				
7/8"			TD90/.875X3	TD90/.875X3.5	TD90/.875X4	TD90/.875X4.5		TD90/.875X5.5				
1"			TD90/1X3	TD90/1X3.5	TD90/1X4	TD90/1X4.5		TD90/1X5.5	TD90/1.00X6	TD90/1.00X6.5		
1-1/8"			TD90/1.125X3	TD90/1.125X3.5	TD90/1.125X4	TD90/1.125X4.5		TD90/1.125X5.5				
1-1/4"				TD90/1.25X3.5	TD90/1.25X4	TD90/1.25X4.5	TD90/1.25X5	TD90/1.25X5.5	TD90/1.25X6	TD90/1.25X6.5	TD90/1.25X7	
1-3/8"						TD90/1.375X4.5	TD90/1.375X5	TD90/1.375X5.5	TD90/1.375X6	TD90/1.375X6.5		TD90/1.375X7.5
1-1/2"						TD90/1.5X4.5	TD90/1.5X5	TD90/1.5X5.5	TD90/1.5X6	TD90/1.5X6.5	TD90/1.5X7	TD90/1.5X7.5
1-5/8"								TD90/1.625X5.5	TD90/1.625X6	TD90/1.625X6.5	TD90/1.625X7	TD90/1.625X7.5
1-3/4"								TD90/1.75X5.5	TD90/1.75X6	TD90/1.75X6.5	TD90/1.75X7	TD90/1.75X7.5
1-7/8"									TD90/1.875X6	TD90/1.875X6.5	TD90/1.875X7	TD90/1.875X7.5
2"								TD90/2X5.5	TD90/2X6	TD90/2X6.5	TD90/2X7	TD90/2X7.5
2-1/8"										TD90/2.125X6.5		TD90/2.125X7.5
2-1/4"										TD90/2.25X6.5		TD90/2.25X7.5
2-3/8"										TD90/2.375X6.5		TD90/2.375X7.5
2-1/2"										TD90/2.5X6.5		TD90/2.5X7.5



SQUARE TUBE BENDER DIES

SQUARE TUBE BENDER DIES 180°											
BEND RADIUS	2.25"	3"	3.5"	4"	4.5"	5"	5.5"	6"	6.5"	7"	7.5"
PIPE SIZE											
1/2"		SD180/.5X3	SD180/.5X3.5	SD180/.5X4	SD180/.5X4.5		SD180/.5X5.5	SD180/.5X6	SD180/.5X6.5		
5/8"	SD180/.875X2.25										
3/4"	SD180/.75X2.25	SD180/.75X3	SD180/.75X3.5	SD180/.75X4	SD180/.75X4.5		SD180/.75X5.5		SD180/.75X6.5		
1"		SD180/1X3	SD180/1X3.5	SD180/1X4	SD180/1X4.5	SD180/1X5	SD180/1X5.5	SD180/1X6	SD180/1X6.5		
1-1/4"					SD180/1.25X4.5	SD180/1.25X5	SD180/1.25X5.5	SD180/1.25X6	SD180/1.25X6.5	SD180/1.25X7	
1-1/2"					SD180/1.5X4.5		SD180/1.5X5.5	SD180/1.5X6		SD180/1.5X7	SD180/1.5X7.5
1-3/4"										SD180/1.75X7	
2"										SD180/2X7	SD180/2X7.5

SQUARE TUBE BENDER DIES 90°										
BEND RADIUS	3"	3.5"	4"	4.5"	5"	5.5"	6"	6.5"	7"	7.5"
PIPE SIZE										
1/2"	SD90/.5X3	SD90/.5X3.5	SD90/.5X4	SD90/.5X4.5		SD90/.5X5.5	SD90/.5X6	SD90/.5X6.5		
3/4"	SD90/.75X3	SD90/.75X3.5	SD90/.75X4	SD90/.75X4.5		SD90/.75X5.5		SD90/.75X6.5		
1"	SD90/1X3	SD90/1X3.5	SD90/1X4	SD90/1X4.5	SD90/1X5	SD90/1X5.5	SD90/1X6	SD90/1X6.5		
1-1/4"				SD90/1.25X4.5	SD90/1.25X5	SD90/1.25X5.5	SD90/1.25X6	SD90/1.25X6.5	SD90/1.25X7	
1-1/2"				SD90/1.5X4.5		SD90/1.5X5.5	SD90/1.5X6		SD90/1.5X7	SD90/1.5X7.5
1-3/4"									SD90/1.75X7	
2"									SD90/2X7	SD90/2X7.5